

Appendix F Structure and Actual Sampling Depth of 3,000 L Underground Fuel Tank of EPSS3 (i.e. BH5)

<u>Sample</u>	<u>Sampling Point Selection Strategy</u>
Sand	0.5 m, 1.5 m below top concrete slab, 1.0m below second concrete slab
Soil	0.5m below base concrete slab

Legend:
 Actual Sampling Point

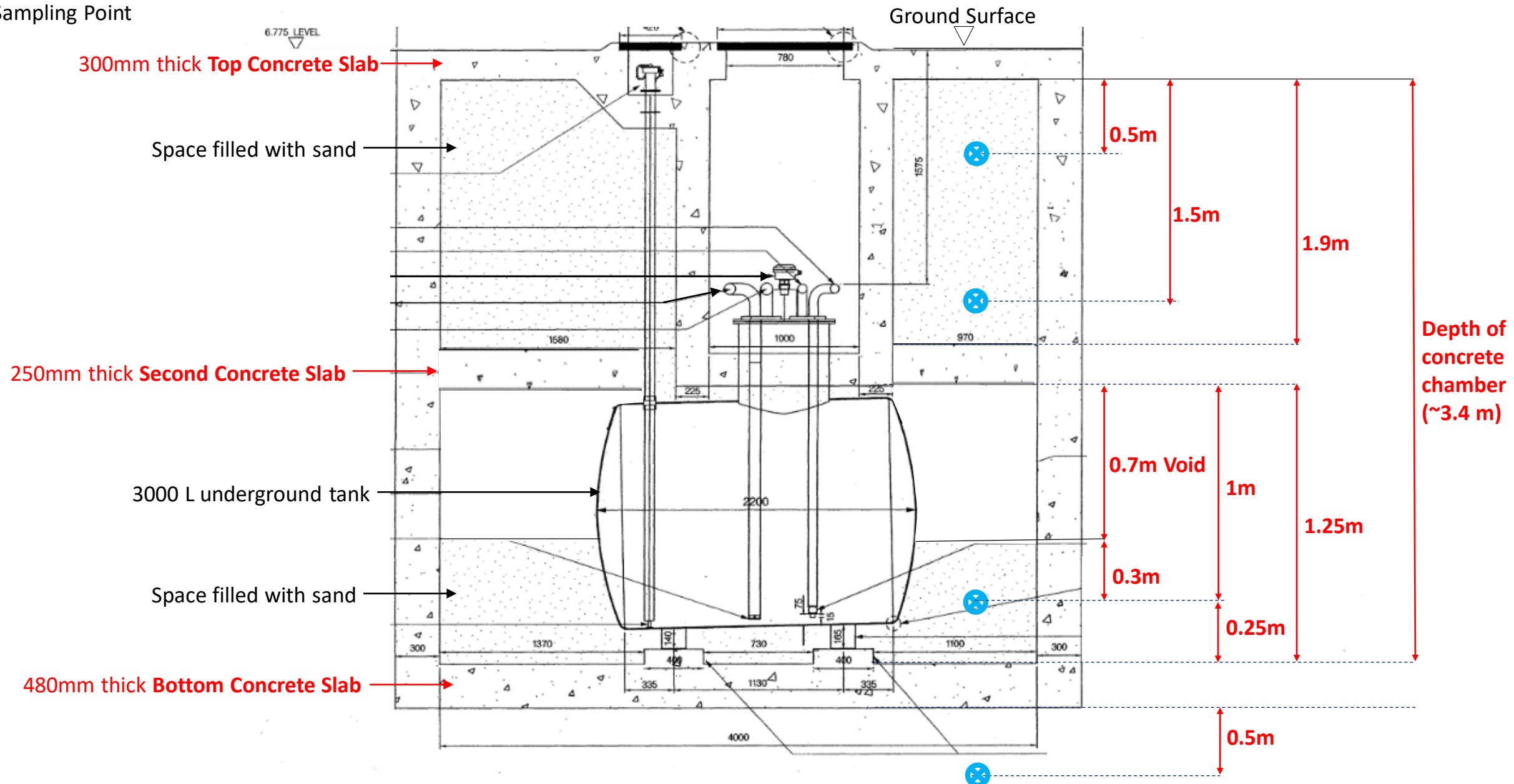

Actual Sampling Point Selection of 3,000 L Underground Fuel Tank of Emergency Power Supply System No.3 (i.e. BH5)